

STRAUB-STEP-FLEX 2 Ø 250.0 - 812.8 mm

Components / Materials	W1	W2	W4	W5
Casing	AISI A106, hot-dip galv.	AISI 316 L / 316 TI		AISI 316 L / 316 TI / S32101 (LDX)
Bolts	AISI 4135	AISI 4135		A4 - 80
Bars	AISI 14 L 14, galvanised	AISI 12 L 14, galvanised		AISI 316 L
Strip insert	AISI 316 L	AISI 316 L		AISI 316 L

Sealing sleeve EPDM Temp.: -20°C up to +100°C
 Medium: all qualities of water, waste water, air, solids and chemical products

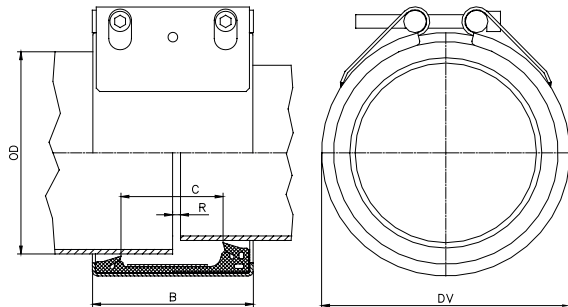

B Width of pipe coupling:
 STEP-FLEX 2 LS = 139 mm
 STEP-FLEX 2 LU = 141 mm
 STEP-FLEX 2 LV = 141 mm
 STEP-FLEX 2 H = 142 mm
 STEP-FLEX 2 XS = 148 mm
 DV Outside diameter of the coupling installed = OD+27 mm
 C Distance between sealing lips = 91 mm
 R_{max} Distance between pipe ends with strip insert = 35 mm
 Distance between pipe ends without strip insert = 10 mm

Pipe 1 OD [mm]	Pipe 2 [min - max]	Working pressure PS [bar]					Torque rate [Nm]				
		LS	LU	LV (LDX)	H	XS	LS	LU	LV (LDX)	H	XS
250.0	220 - 280	12.0	24.0				15	30			
267.0	237 - 297	11.0	22.5				15	30			
273.0	243 - 303	11.0	22.0	25.0	25.0	25.0	15	30	40	30	110
304.0	274 - 334	10.0	19.5	25.0	25.0	25.0	20	30	40	30	110
323.9	293 - 353	9.5	18.5	25.0	25.0	25.0	20	30	40	30	110
355.6	325 - 385	8.5	17.0	25.0	25.0	25.0	20	30	40	30	110
406.4	376 - 436	7.5	15.0	25.0	22.0	25.0	20	30	50	40	120
457.2	427 - 487	6.5	13.0	25.0	19.0	25.0	20	40	50	40	120
508.0	478 - 538	6.0	12.0	24.0	17.0	25.0	25	40	60	40	120
558.8	528 - 588	5.5	10.5	22.0	16.0	25.0	25	40	60	50	140
609.6	579 - 639	5.0	10.0	20.0	14.0	25.0	25	40	60	50	140
711.2	681 - 741	4.0	8.5	17.0	12.0	25.0	30	50	70	50	140
762.0	732 - 792	4.0	8.0	16.0	12.0	23.5	30	50	70	60	160
812.8	782 - 842	3.5	7.5	15.0	11.0	22.0	30	50	70	60	160

STRAUB produces custom made couplings from 250.0 up to 812.8 mm

Remarks:

- Follow fitting / disassembly instructions
- PS = Working pressure considering the application loads
 Test pressure = PS x 1.5 (for example industry, water supply etc.)
 Burst pressure = approx. PS x 2
- Stainless steel strip insert included
- Available in one-piece version only
- LS- and LU-version in W2 or W5
- LV(LDX)-version in W5
- H- and XS-version in W1

For IPS sizes in bold see technical manual for actual OD